

NOVA Energy & Automation



Product Specifications

Room Light and Warning Light Control Cabinet

Model NEA020SS-CA

A 3D perspective rendering of a control cabinet. The cabinet is dark blue with a metallic finish. It has a large front panel on the left and a smaller panel on the right. The cabinet is shown from a low angle, highlighting its depth and the shadows cast by its edges. The date "01 October 2012" is printed in white on the right-hand panel.

01 October 2012

Product Description

1. Standard Applications

The Nova NEA020SS-CA is an integrated lighting controller designed to meet the hospital-grade lighting power requirements of medical imaging suites. The low voltage control panel provides a safe, low voltage interface between the imaging equipment, warning lights, room lights, operator's control, and room line voltage.

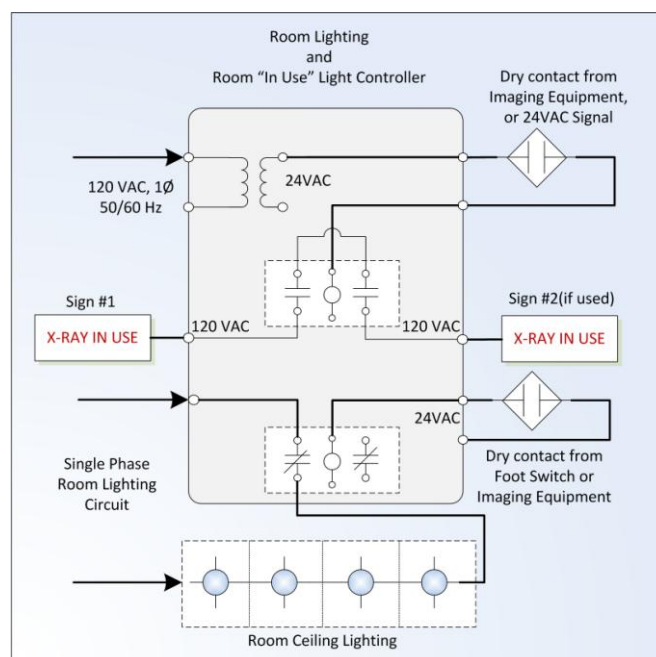

Figure 1 Nova Warning & Room Light Controller Application Diagram

2. System Compatibility

The Nova NEA020SS-CA is compatible with the following medical imaging equipment:

GE Medical Cath Lab, Single Plane, Bi Plane models: Innova 2100, 3100, 4100 Plus, IQ Optima, 2121, 3131, Hybrid OR, and several other similar installations.

GE Medical R&F models: Precision 500D, Precision RX/i and several other similar installations.

3. Identification

GE Healthcare- The proper panel can be identified on GE Healthcare Drawings:

sheet E1 → Junction Point Descriptions → XRLC Warning Light controller:

Equal to E4502SS, E4500CA, E4500AL

4. Features/ Benefits

Features

- Integrated design provides all of the lighting controls into an easy to configure panel
- Includes specification grade foot pedal control switch
- Utilizes heavy duty contacts to handle room light currents.
- Controls up to 2 separate warning lights
- UL and cUL listed to conform to NEC.
- Labeled to conform with NFPA99, NFPA-70.
- Provides a fixed junction point for the lighting system
- Compact size for easy installation
- Short circuit and overload protection
- Thermal protection
- No minimum load required
- Factory wired and tested.
- Simple field configuration can accommodate several different equipment installations.
- Integrated "Hospital Supplied" 24VAC power source

Benefits

- Reduced weight- all components are within a small 20lb enclosure
- Eliminated the multiple lighting control systems
- Reduces installation time and cost by eliminating delays in obtaining individually enclosed components and by eliminating on site assembly.
- Provides a standardized platform for other future modifications or upgrades.

5. Specifications

Model	NEA020SS-CA
Application	Warning Light and room light controls for medical imaging equipment
Input Voltage	110VAC
Input Current	AC input (maximum): 12 A
Output Voltage	Internally derived 24VAC for controls
Maximum Lighting Load	20 Amps
Warning Light Controls	Compatible with up to 2 warning lights , LED or incandescent
Room Lighting Voltage	120/240/277VAC
Foot Pedal Switch	Integrated controls for foot pedal switch, (foot pedal and 100ft cord included)
Approvals	UL/cUL

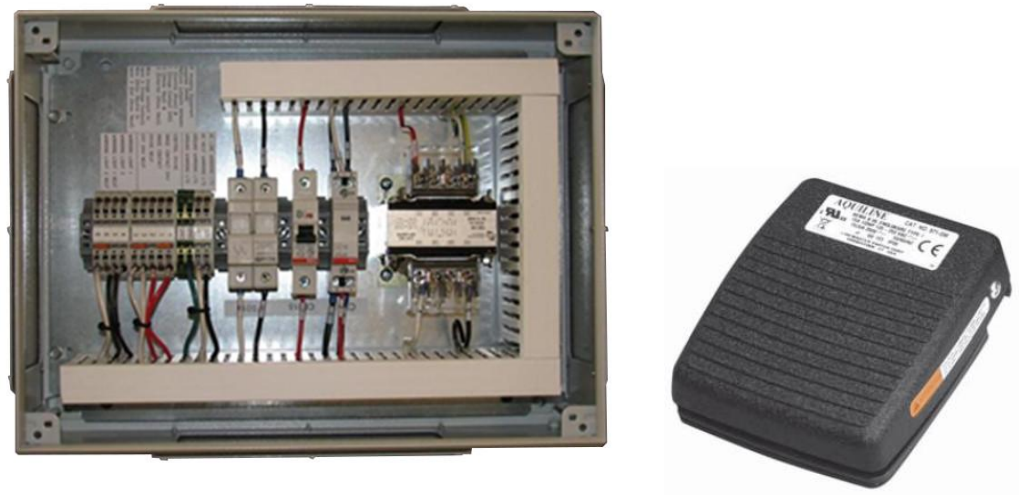

Figure 2 Nova Warning & Room Light Controller- Inside

6. Weight and Dimensions

Mounting	Warning and Room Lighting Controller is provided in a steel enclosure suitable for surface, wall or above the ceiling mounting.
Dimensions	Height: 12" (300mm) Width:8" (200mm) Depth: 6" (150mm)
Weight	21 lbs. (9.5 kg)
Mounting	Rear wall mounting holes (4). Spaced 0.79" (20mm) from enclosure edge. Optional mounting brackets are available
Enclosure	16 Gauge Carbon Steel, all rounded corners 1 gland plate in the enclosure base.
Enclosure Sealing	Foamed-in place polyurethane door gasket
Finish	Dip coat primed, powder coated in textured RAL 7035
Cover	Screw type cover
Interior Panel	Zinc-Plated subpanel
Protection Category	IP 66 to EN60 529/09:2000, complies with NEMA 4 Enclosure Approvals: UL, CSA, TUV, GL, Lloyds, VDE, Bureau Veritas



Figure 3 Nova Lighting Controller- Outside

All four sides have removable gland plates for easy mounting of conduit fittings.

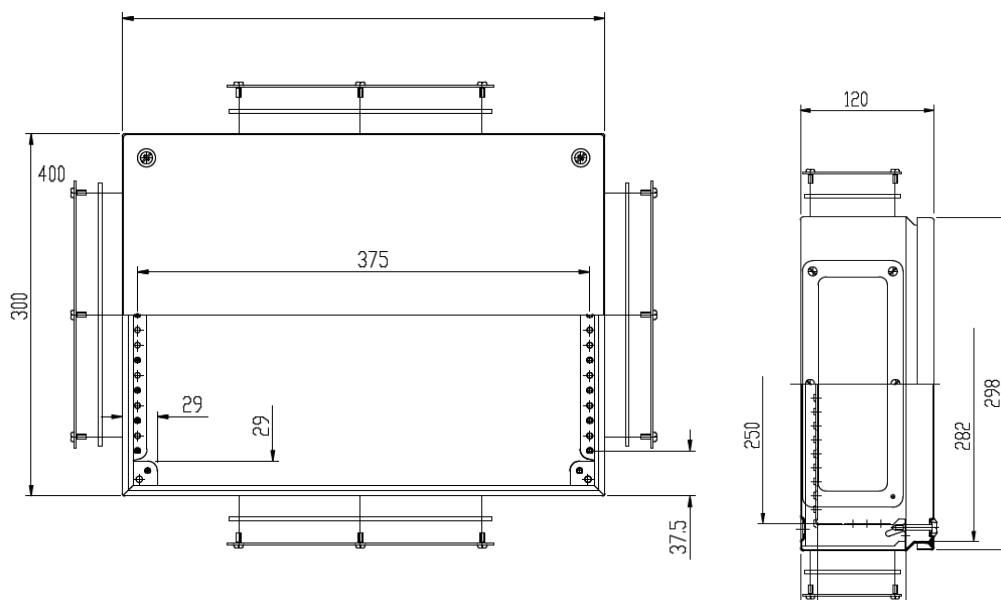

Figure 4 Enclosure Dimensions (mm): Outside, Depth

7. Warranty

This limited warranty set forth below is given by Nova Automation (“Seller”) with respect to the electrical equipment (“Product”) packaged with this limited warranty. The Product, when delivered to you in new condition in its original packaging, is warranted against defects in materials or workmanship as follows: For a period of one (1) year from the date of original purchase, defective parts or a defective Product returned to a Seller, or its authorized service providers, as applicable, and proven to be defective upon inspection, will be repaired, or exchanged for a new Product, as determined by the Seller, or the authorized service provider.

This limited warranty covers all defects encountered in normal use of the Product, and does not apply in the following cases: Loss of or damage to the Product due to abuse, mishandling, alteration,

accident, electrical current fluctuations, failure to follow operating, maintenance or environmental instructions prescribed by Seller, failure to follow Sellers installation instructions, or service performed by someone other than Seller or its authorized service provider.

Nova assumes no responsibility for labor or freight costs incurred in connection with the installation, removal, or replacement of products determined to be defective or any consequential or incidental damages arising from the use of the product. Nova Automations entire liability on any claim of loss or damage resulting from a defective product is limited to the replacement of the product.

WARRANTY IS VOID IF PRODUCT IS NOT USED FOR THE PURPOSE FOR WHICH IT WAS MANUFACTURED.

8. Product Service and Technical Assistance

Nova Automation, LLC
2722 N. Avondale Blvd
Milwaukee WI 53210
PH# 262-309-2950
Website: www.NovaAutomation.net

9. Approvals

Prepared By _____
([Job Title])

This document requires the following approvals

Approved By _____
([Job Title])

([Job Title])

Approval Date _____